



INTEGRAMplus : Access to silicon & polymer based technologies for MEMS and Bio / fluidic Applications

Chris Pickering, QinetiQ, UK



Outline of talk

- Introduction
- INTEGRAM*plus* consortium
 - Project aims and focus
 - Partner capabilities
- INTEGRAM*plus* prototyping platforms and service offers
- INTEGRAM*plus* multi-domain technology platforms and demonstrators
 - MEMS-electronics microsystems
 - Silicon-polymer integration
 - Microfluidics-based microsystems
- Summary



INTEGRAM*plus* - Integrated MNT Platforms and Services

FP6 Europractice Integrated Project

Aim: Highly integrated microsystems combining smart Si functionality with polymer platforms in a multi-domain environment

- Address and stimulate future market needs via higher levels of integration in stable, manufacturable MNT processes
 - **Multi-domain integration:** bio-optical-fluidics, MEMS-electronics
 - **Mixed process technologies** (silicon-polymer)
- Stimulate take up of smart (integrated) MNT products and reduce access barriers
 - provide development platforms and standard modules
- Provide low cost MNT prototyping services
 - Silicon MEMS and polymer prototyping services
 - with route to volume based on Design for Manufacture principles
- Provide seamless service across the MNT supply chain
 - from concept to production
 - 10 partners from 7 countries + extended supply chain network



INTEGRAMplus Consortium

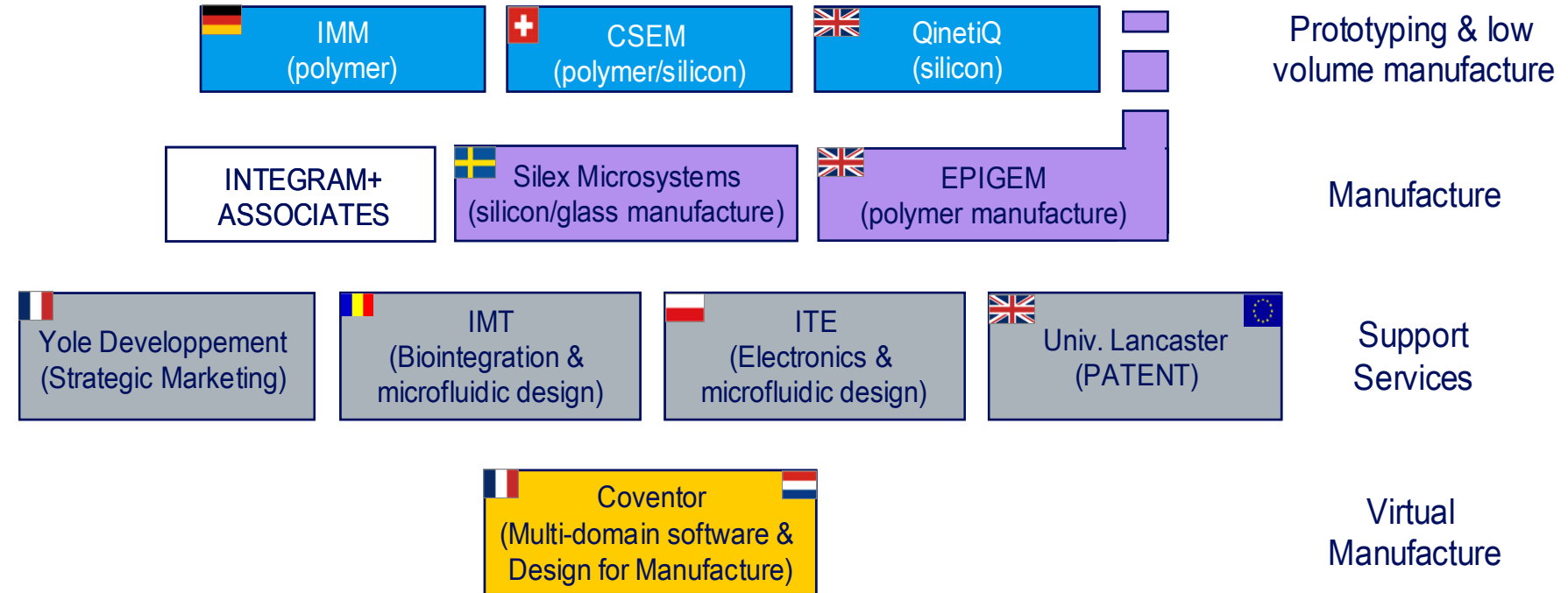

SUPPLY CHAIN PARTNERS

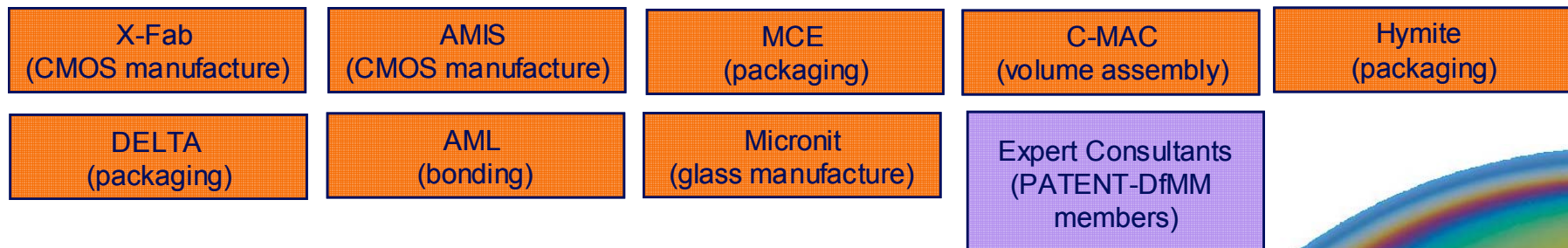

The INTEGRAMplus Partners' Technology Portfolio

European partners in micro and nanotechnologies with complementary expertise in:

- Silicon, polymer, glass, hybrid solutions
- Multi-domains (optics, fluidics, MEMS, bio, chemical, electronics)
- Multi-level integration (material, electronics, functions and system)
- Development and production along the supply chain

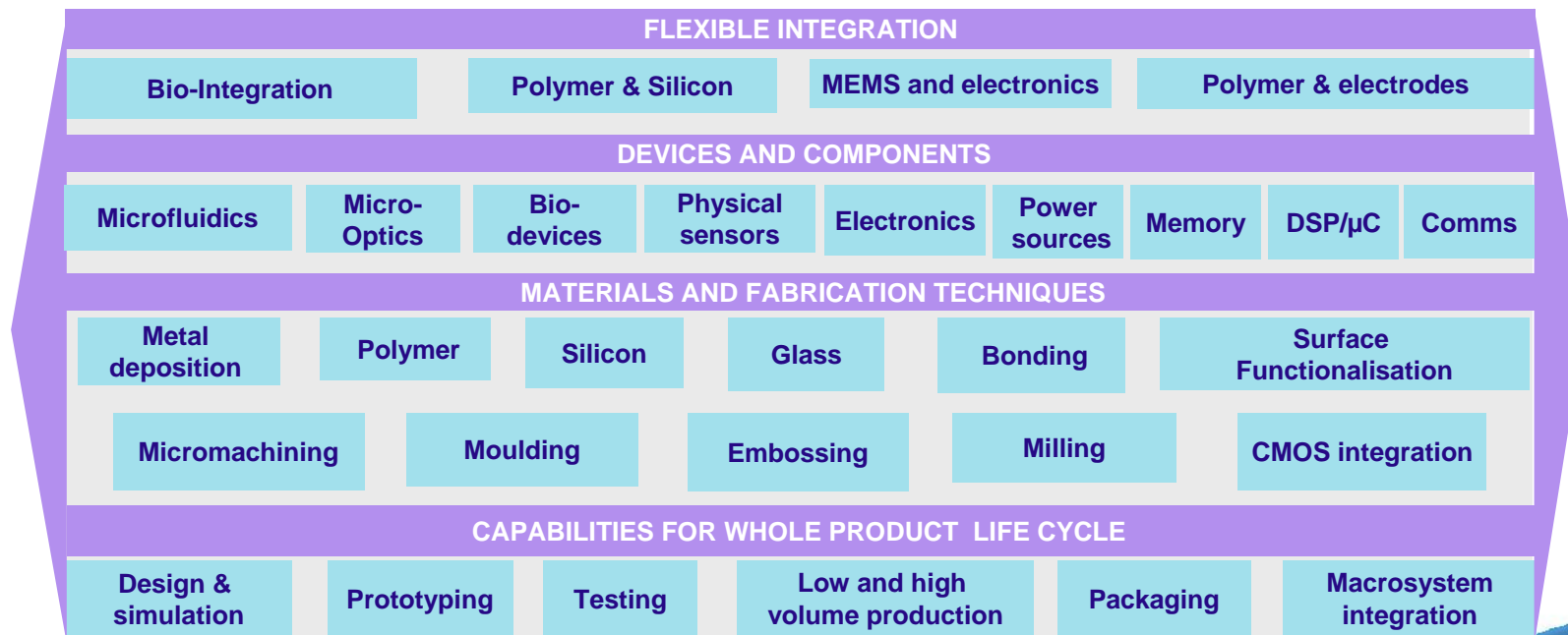

How to engage with INTEGRAMplus

INTEGRAMplus partners can assist at all the stages of the product development lifecycle

INTEGRAMplus can minimise risk by identifying and providing:

- the most appropriate technology
- design and simulation tools compatible with your CAD tools
- standardised tried and tested prototype and development facilities
- route to manufacturing

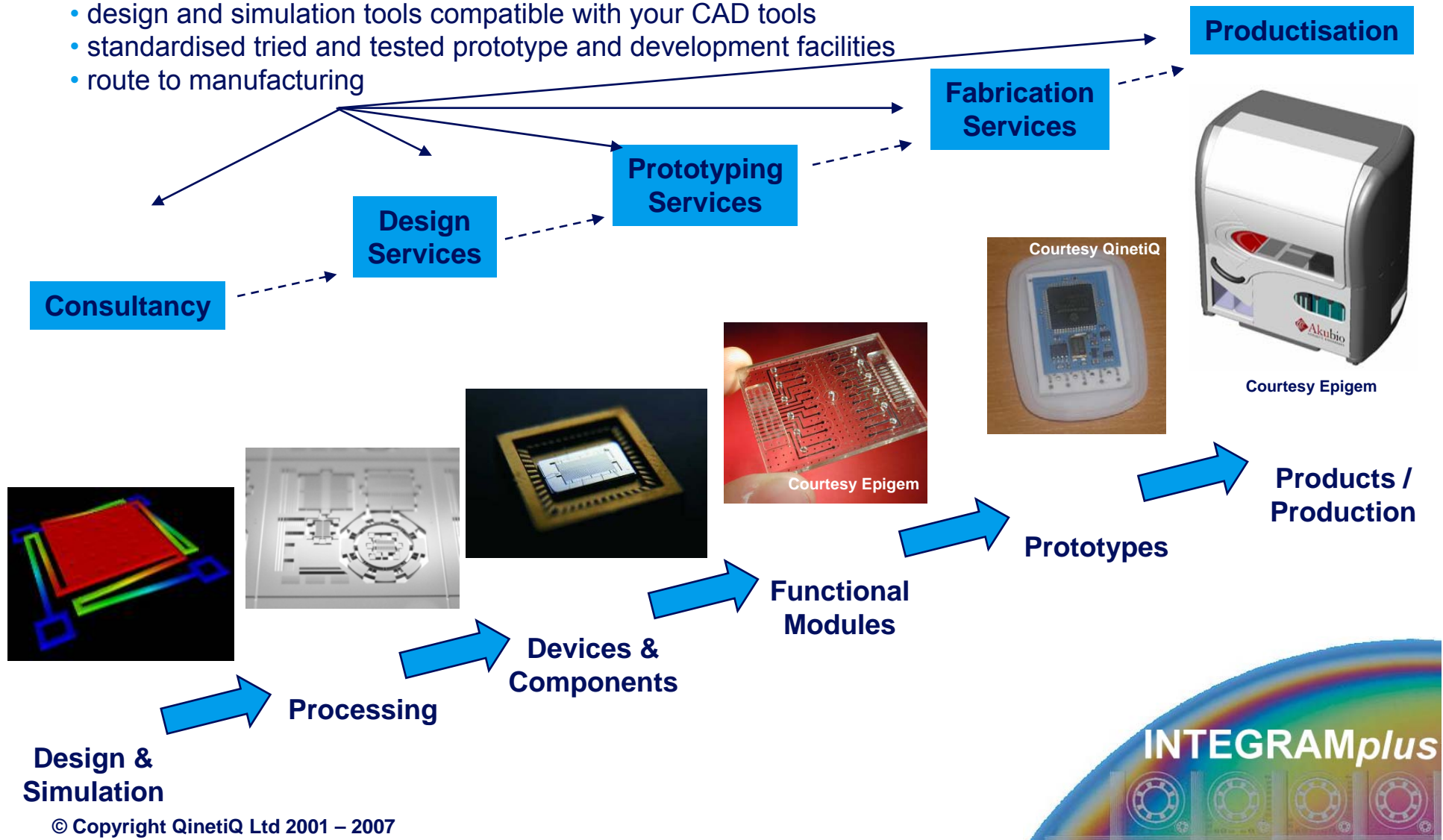

Current Service Offerings

Service Offering No.1 (Fixed price – scheduled runs)

- ‘Knowledgeable Customers’ (with in-house design expertise) requiring Proof of Concept devices – Universities, SMEs
 - Design Rules/Guidelines
 - Scheduled MPW/SPW MEMS and low-cost microfluidic prototyping services

Service Offering No.2 (POA)

- Industry and SME customers with a functional specification
 - Consultancy, Simulation, Design, Custom fabrication, Functional test
 - Product development, devices supplied to customer with route to manufacture

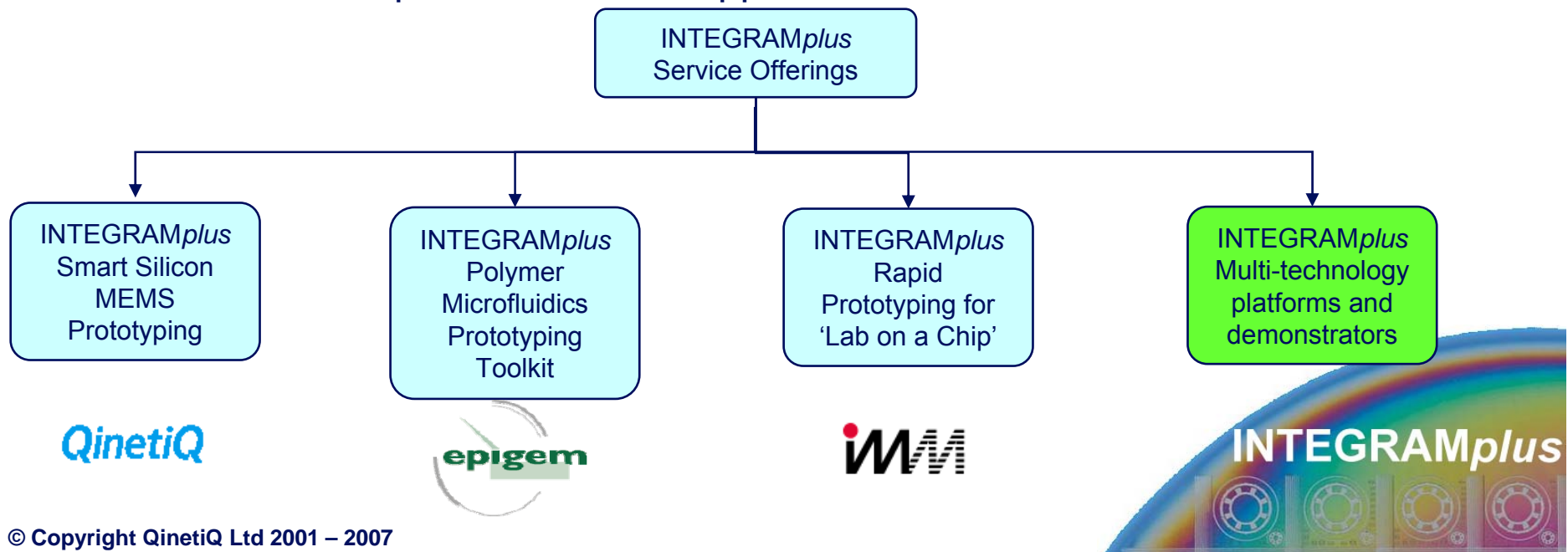

INTEGRAM^{plus} Silicon MEMS Prototyping Platforms

QinetiQ

- INTEGRAM Metal-nitride Prototyping Kit (MPK)
 - Metal-nitride sacrificial surface micromachining with integration via vertical or lateral post-processing on CMOS
- INTEGRAM Polysilicon Prototyping Kit (PPK)
 - Polysilicon sacrificial surface micromachining
- INTEGRAM Deep Prototyping Kit (DPK)
 - DRIE high aspect ratio micromachining of SOI and bulk silicon
- Validated Design Handbook including MEMS design rules, detailed process description, materials data and case studies for selected devices, incorporated in CoventorWare
 - material property database (*.mpd)
 - process emulation files (*.proc)
 - layout template files (*.cat, *.gds)
 - library of parametric and non-parametric elements
 - design rule checking

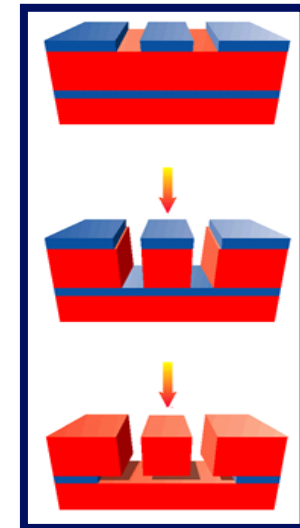
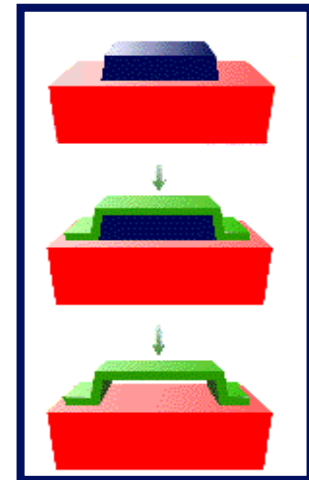

Multi-Project Wafer (MPW) and Single-Project Wafer (SPW) Runs

MPW

- Mask and run costs shared between customers for lowest cost of entry
 - multiple customer designs on each wafer
 - results in a small number of die (20) for each customer
- Processes tightly specified
 - designs must not risk impacting die for other customers
 - fixed die size (4.5mm user area) / no scope for process variations

SPW

- Small batch size in standardised process sequence to control cost
 - single customer design per wafer
 - cost depends on number of wafers ordered (1-2)
 - results in a moderate number of die (<140) to customer

SOI micromachining (DPK)

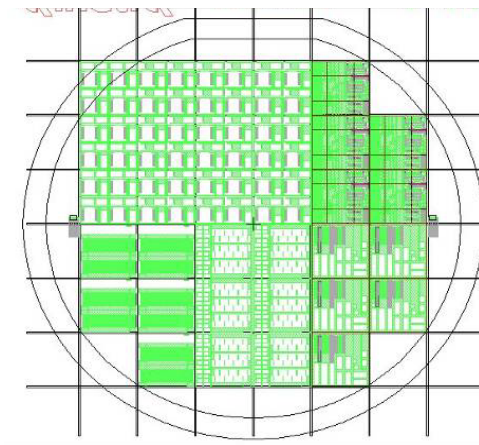

- Accelerometers, gyroscopes & magnetometers
- VOAs, switches & waveguides
- Resonators
- Test modules

Metal-Nitride Surface Micromachining (MPK)

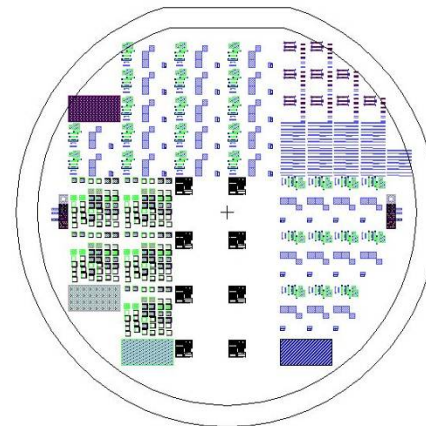

- Accelerometers
- Ultrasonic sensors
- Switches & varactors
- Micromirrors arrays
- Test modules

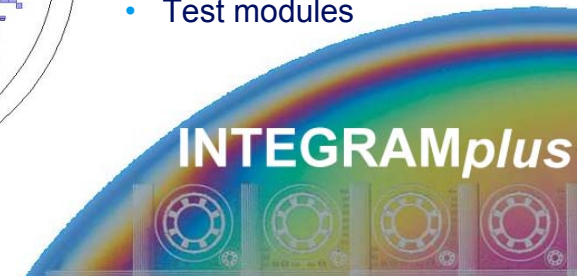

Fluence™ Microfluidic prototyping toolkit

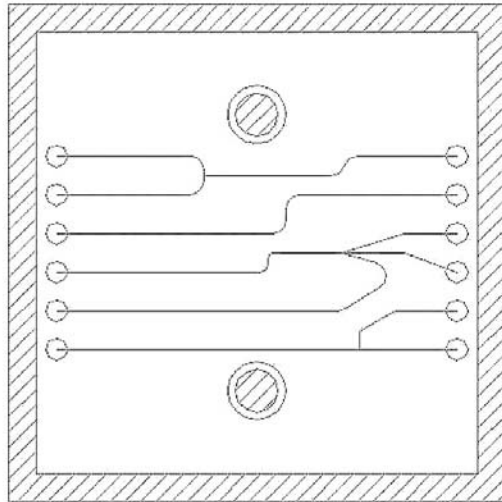

Fixed price prototyping offer

- Firm design rules with fixed depth of fluid channels (either 50 or 100µm)
- Width of fluid channels must be between 20 and 800 µm

Custom microfluid chip offer

- Rapid prototyping/manufacturing service with low cost tooling
- Wide range of channel widths and depths available
(from mm down to 20 µm width and 5 µm depth)
- Multilayer fluid circuits can be made (up to 10 + layers demonstrated)
- Mixed depth features on the same chip
- Electrodes or heater elements incorporated into chips
- Ferrule interconnection system for compact and leak-free fluid interfacing
- Micro-gasket sealing for integration of silicon/quartz/glass components

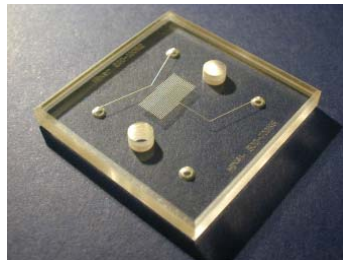

Microfluidic chip



Epigem Fluence™ toolkit

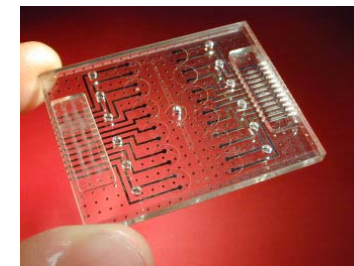

Microelectrodes



Modular rapid prototyping platform for Lab-on-Chip

- Microfluidic system with sample preparation and PCR analysis, demonstrated for soil / water sampling

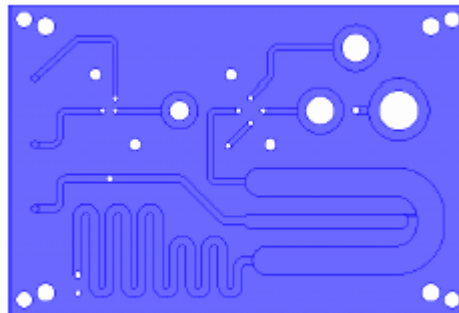

Filtration and lysis of bacteria cells

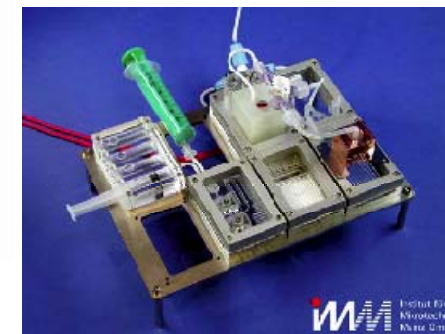
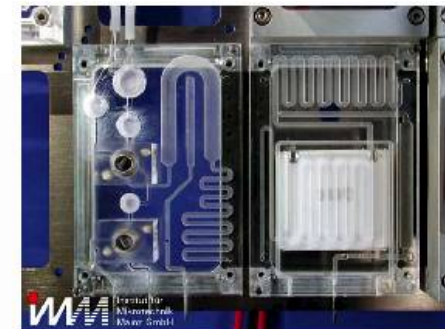
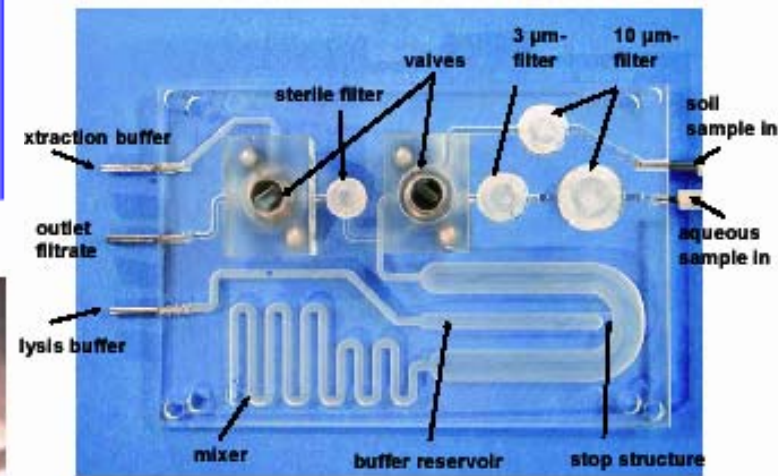

Current Service Offerings

Service Offering No.1 (Fixed price – scheduled runs)

- ‘Knowledgeable Customers’ (with in-house design expertise) requiring Proof of Concept devices – Universities, SMEs
 - Design Rules/Guidelines
 - Scheduled MPW/SPW MEMS and low-cost microfluidic prototyping services

Service Offering No.2 (POA)

- Industry and SME customers with a functional specification
 - Consultancy, Simulation, Design, Custom fabrication, Functional test
 - Product development, devices supplied to customer with route to manufacture

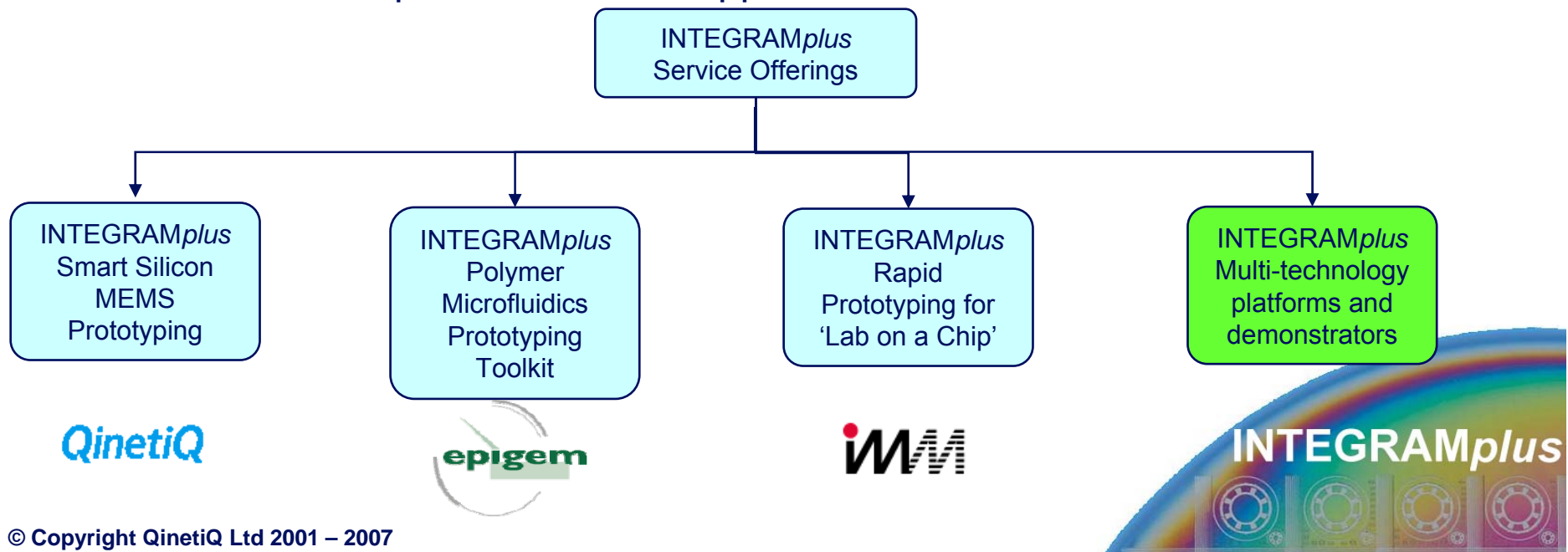

INTEGRAM^{plus} multi-domain platform

MEMS/electronics integration with route to volume (Silicon microphone)

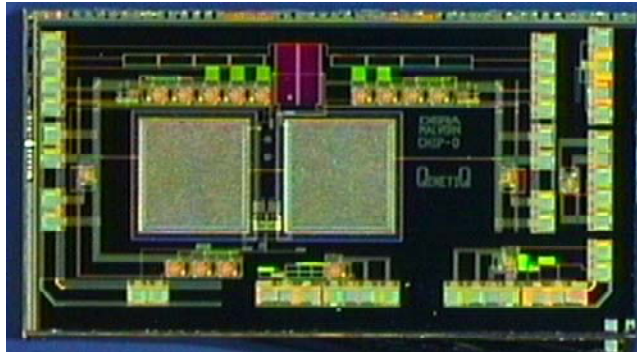
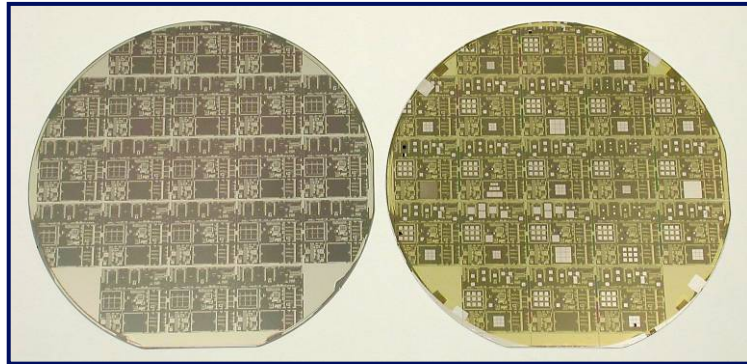

- **Monolithic**

- Custom MEMS/CMOS design
- Post-processing on custom-designed CMOS wafers from Associate Partner
- CAD tools for co-design

- **Hybrid**

- Access via QinetiQ MPW/SPW MEMS and via Associate CMOS Foundry Partner or Europractice IC Service
- Consultancy available (CAD co-design)
- QinetiQ or customer designs for MEMS and/or ASIC
- Volume manufacture route available

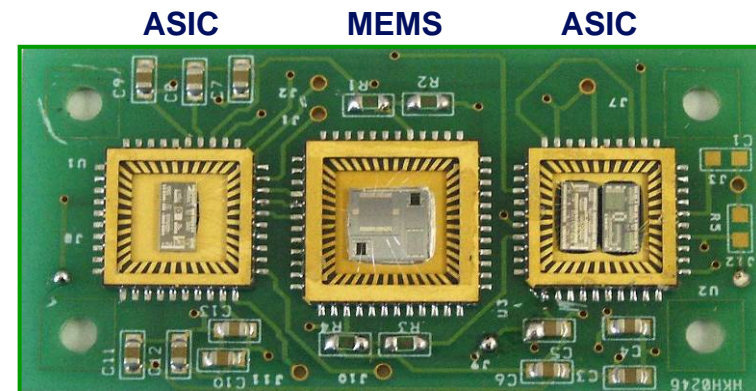

INTEGRAM^{plus} multi-domain multi-technology platforms (under development)

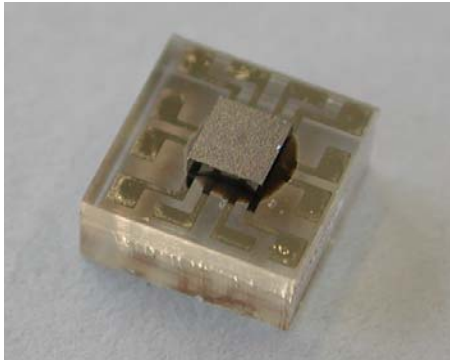

Flipped Si chip assembled with ACA on PMMA substrate with metal tracks

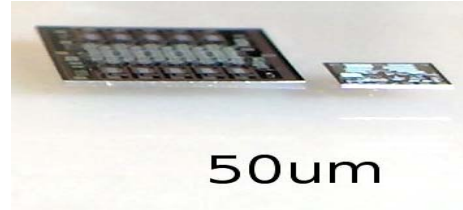
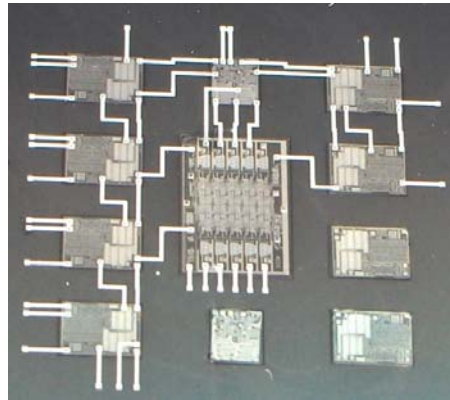

Thinned Si chips in cavities in Si wafer with polymer

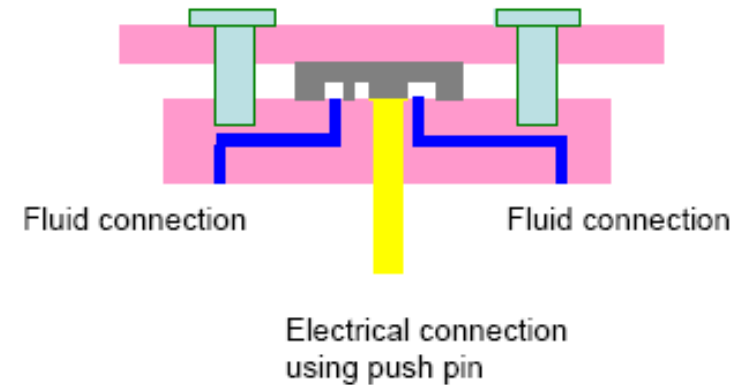

Si chip scale package with polymer microfluidic chip and electrical connections

Innovative silicon-polymer integration technology for chips onto substrates with interconnections and fluidics



INTEGRAM*plus* multi-domain integration platform

Combined microfluidic and optical platform

- Rectangular (square) cross-section light canals
 - Support single or multi-mode propagation
 - Low loss, high fidelity, broad band
 - Range of monolithic optical functions “for free”
 - Large step index confines mode to air/fluid core
- Canals also act as fluidic channels
 - Light and fluid guided and interact in same channel
 - Change in optical transmission/fluorescence
 - Optical (cell) excitation, analysis and/or manipulation
 - Microfluidic functions easily integrated
 - Ready to accept detection chemistry

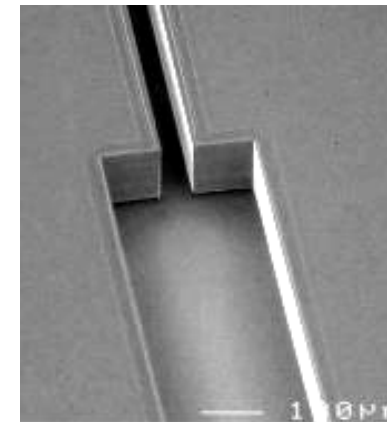
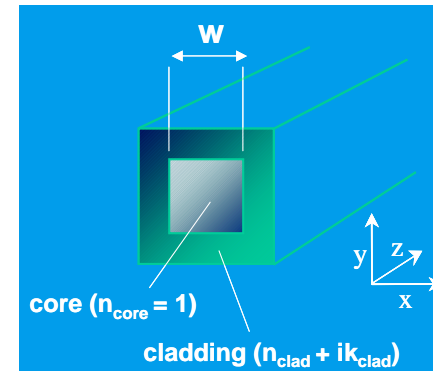

Hollow waveguide
(without lid)

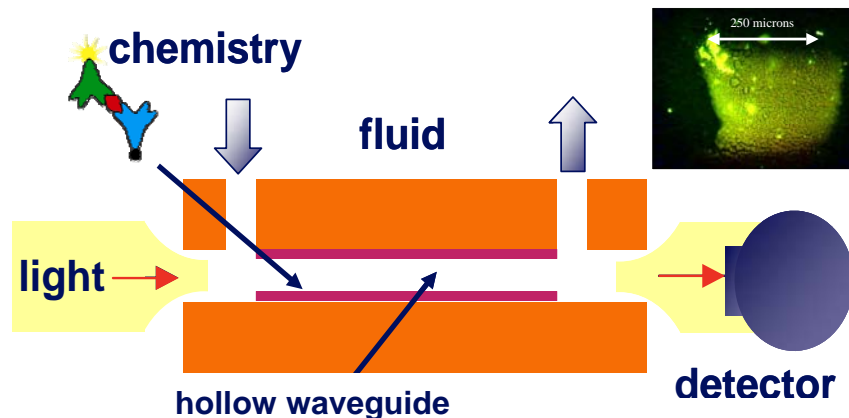

INTEGRAMplus multi-domain demonstrator platform

Modular bio-diagnostics system

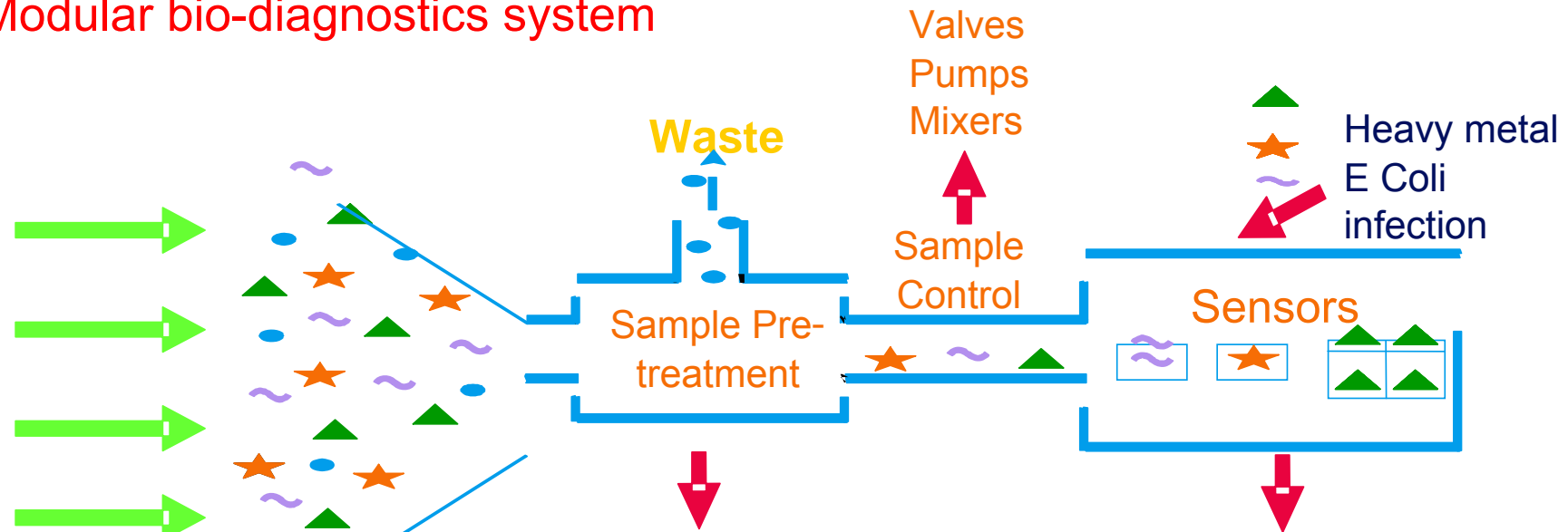

Sample collection
Suitable for large volume



Lysis
Preconcentration
Purification

HWG bio-sensor
PCR
ISFET
etc

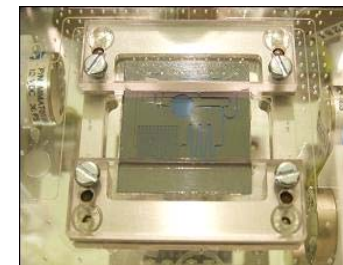

Multi-function integration approach for a customised solution

From your specification, we will adapt our know-how to meet your requirements

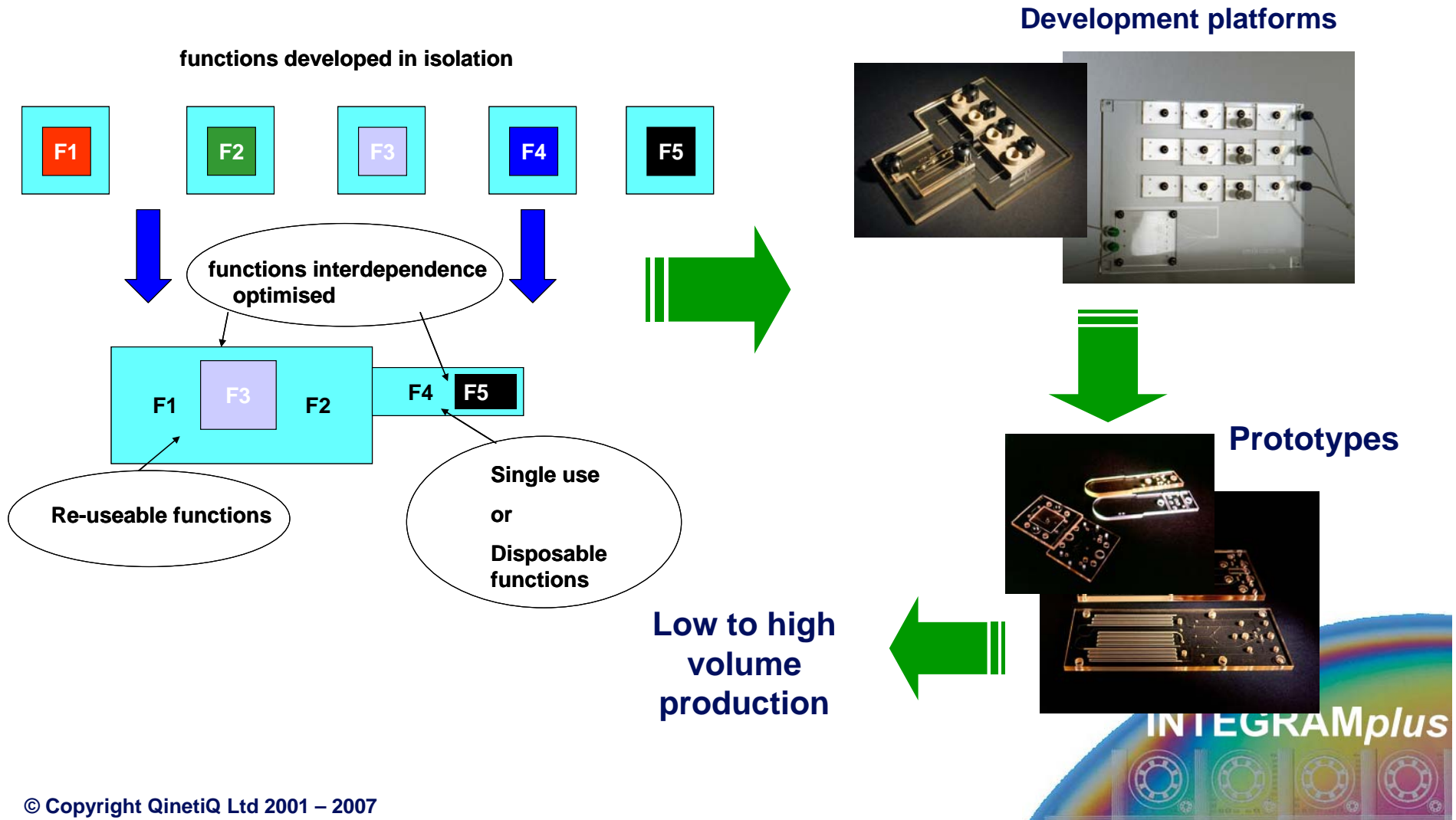

INTEGRAM*plus* Summary

- Provides industry with a world-leading facility to stimulate take-up and accelerate time-to-market of smart mixed-technology components and solutions.
 - A consortium offering tried and tested micro and nano technology expertise from 10 partners operating across 7 European countries.
 - A design and prototyping service with route to volume manufacture for highly integrated microsystems.
 - High degree of flexibility to address the need for increased complexity in microsystems without sacrificing the requirement for manufacturable processes.
 - A flexible customer interactive approach ensures access to INTEGRAM*plus* at any stage in the product lifecycle.

Access via low-cost prototyping services with or without design/consultancy

OR in collaboration to define and specify application demonstrators



Acknowledgements

- European Commission for partially funding this work and Simon Bray for managing the project
- INTEGRAM*plus* partners and associates for all their work in contributing to this paper
 - Co-Authors:
 - Mark McNie, Chris Reeves, Tim Cox & Mike Jenkins (QinetiQ)
 - Christian Bosshard, Helmut Knapp, J Auerswald, A-C Pliska, M Fretz (CSEM)
 - Tom Harvey, Tim Ryan (Epigem)
 - Pawel Janus (ITE)
 - Gerold Schröpfer (Coventor)
 - Frithjof von Germar (IMM)
 - Bogdan Firtat, Carmen Moldovan (IMT)
 - Tomas Bauer (Silex)
 - Andrew Richardson (Lancaster Univ)
 - Geraldine Andrieux (Yole)



INTEGRAMplus - Big Business from Small Beginnings

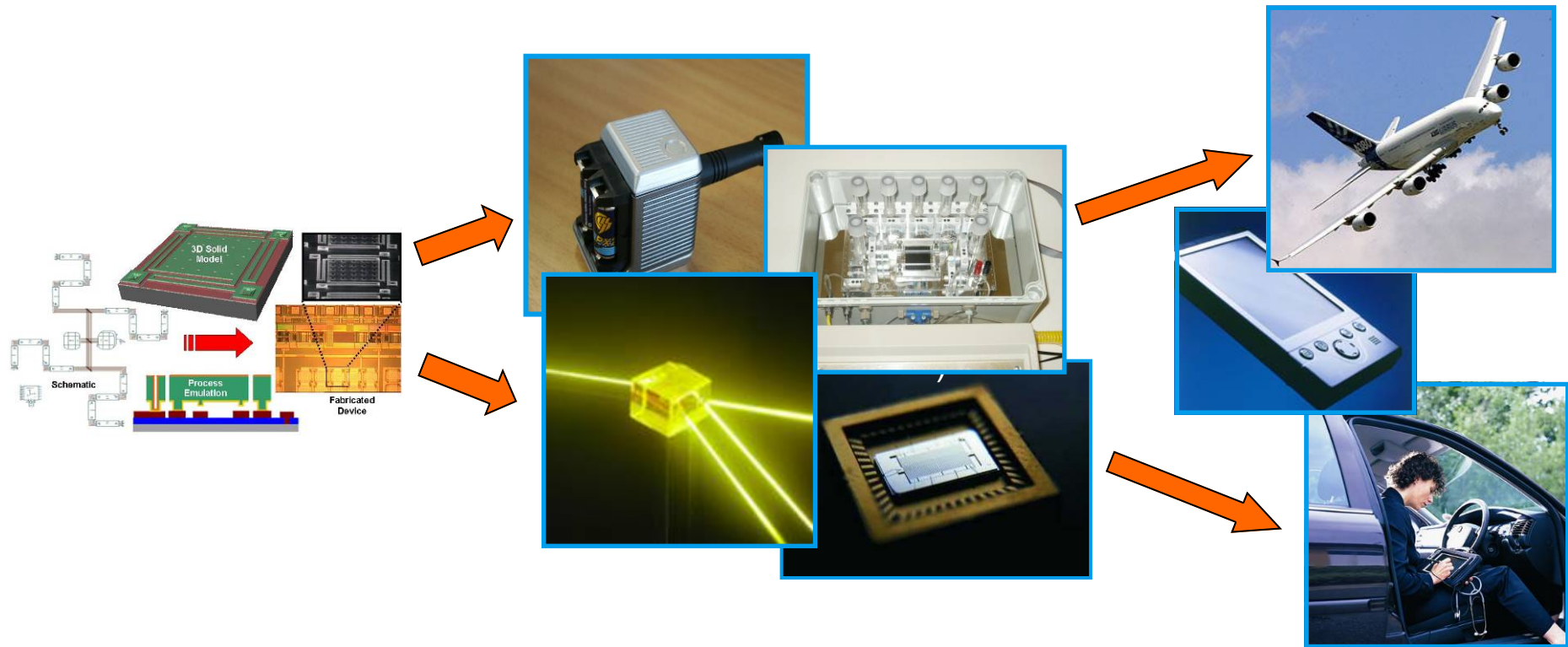

Web-sites: www.integramplus.com
www.QinetiQ.com/mems

Email: info@integramplus.com

Tel: +44(0)1684896262

